

Hope Tote

Designed by Whistler Studios
Featuring the Think Pink Collection by Rosemarie Lavin Design
Size: 19 1/2" x 19 1/2" x 4 1/2"



Check www.windhamfabrics.com Free Project section to see if there are any pattern updates before you start your quilt project

WINDHAM FABRICS

812 Jersey Ave ~ Jersey City, NJ 07310 ~ 201.659.0444 ~ FAX: 201.659.9719
www.windhamfabrics.com email: retail@windhamfabrics.com

Hope Tote

Page 2

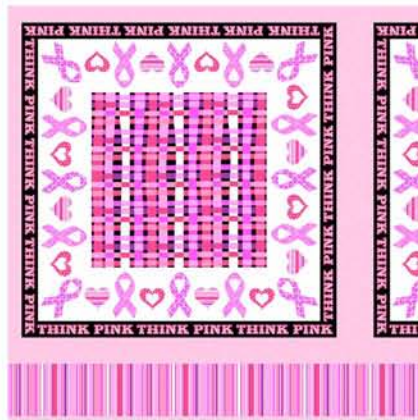

39706P-1

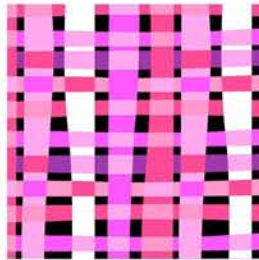

39708-X



39709-1



39710-3

Fabric Requirements:

- (2) Bandana Scarf Blocks 39706P-1 Pink (including stripe at the bottom of 2 panels)
- 5/8 Yard 39710-3 Fuschia Small Set Ribbons
- 1 yard 39709-1 Pink Large Tossed Ribbons
- 5/8 yard 39708-X Multi Plaid
- 5 yards 1/8" piping - store bought preferred (approximately 2 packages)
- Heavy Cardboard or Heavy Weight Pellon for Tote Bottom insert 19 3/4" x 4 3/8"
- Batting
- 1/2 yard of Fusible Fleece for Handles

Cutting:

36406P-1 Pink - Bandana and Stripe

Cut (2) Bandana Squares about 20" x 20" for Front and Back of Tote

Note: If they are not perfectly square, it is OK as the bag will come out OK. Just match width and height when sewing.

Cut (2) 21 1/2" x 4 3/4" for Handles *See note below under 36409-1 Pink

39710-3 Fuschia Small Set Ribbons

Cut (3) 5" x 20" for Side Panels and Bottom

Cut (1) 5" x 14" for Bottle Pocket

39709-1 Pink Large Tossed Ribbons

Cut (2) 20" x 20" for Tote Lining

Cut (3) 5" x 20" for Lining Sides and Bottom

Cut (1) 20" x 9 3/4" for bottom insert

39708-X Multi Plaid

Cut (2) 4 3/4" x 21 1/2" for Handles

***Cut this only if you do not have the 39706P-1 stripe for handles

Cut (1) 20" x 13 1/2" for Inside Pocket

Hope Tote

Page 3

Batting

Cut (2) 21" x 21" (a little larger so you can trim excess later)

Fusible Fleece

Cut (2) 21 1/2" x 4 3/4" for Handles

Assembly:

All seams are 1/4" unless otherwise specified



White = right side



Gray = wrong side

Outside of Tote

1. Take the front and back of the tote, sides and bottom and quilt as you like. Note the lining is separate from the quilted face of the tote so if you want a backing to sandwich your batting between, then you will need 5/8 yard of a plain fabric to use for the backing. Trim any excess batting to fit.
2. On the Front and Back tote pieces, slightly round the bottom corners of the tote. This will make it easier to attach the piping.
3. Take piping and following manufacturer's recommended instructions, attach it to the tote face. Starting at the top of one side, machine stitch around all three sides of the tote. Repeat for the opposite side of the tote. Set aside extra piping for later use.
4. Take handles and attach fusible fleece following manufacturer's recommended instructions. Fold and sew side and one short end. Trim excess seam allowance from fleece. Carefully turn.
Note: to turn easily try Turn-It-All © - a handy tool for easily turning narrow pieces
(Fax: 435-673- 3834 for more information if your local quilt shop does not carry it)
5. Press with seam at center of handle tube. D1
Stitch each side of the handle 1/4" from the edge. D2

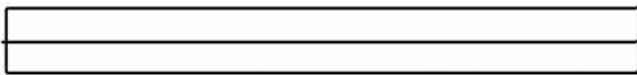

D1

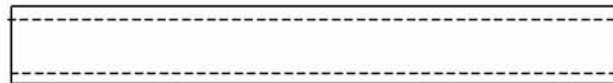

D2

6. Make a notch /mark at the center of each side of bag top opening. Measure 3" from each side of the mark. This will indicate position for the handle edge. Pin the handle to the top edge of the bag on the RIGHT side of the tote. Extend the handle 1/4" past the top edge. Stitch 1/8" from edge over each end of handle. Stitch again to reinforce as handle will hold weight of bag.

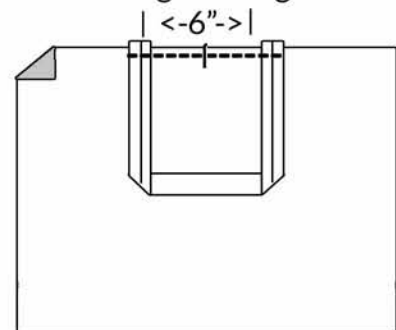

Hope Tote

Page 4

- Take bottle pocket piece and fold in half to be 7" long. Place on bottom edge of one side panel with the folded side up. D3 Edge stitch down each side to hold in place. Reinforce at the top edge on each side as pocket will receive a lot of use.
- Join the bottom to each side panel.
- With right sides together, take one side of the tote, and pin insert along all 3 sides around the tote. Sew together. Repeat for the other side of the tote. Set aside.

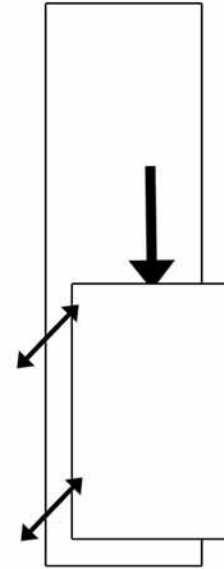

D3

Lining:

- Take inside pocket piece (20" x 13 1/2") and with right sides together, fold in half lengthwise. Stitch the long side closed, turn and press flat. D4



D4

- Place 4 3/4" from top edge of one side of the lining. Pin to hold in place. Edge stitch down one side, across the bottom and up the other side. Divide the long pocket into 3 smaller pockets by adding 2 vertical stitch lines about 6 1/2" apart. Reinforce at the top edge to secure. D5

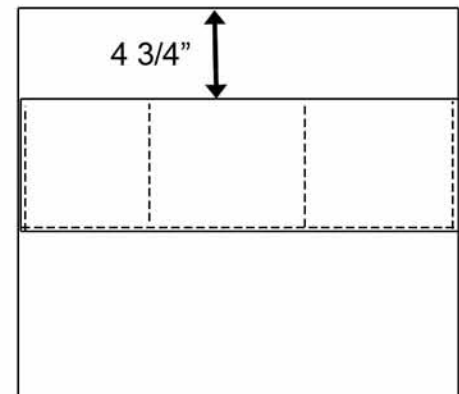

D5

- Take the 2 large lining pieces and curve the bottom corners as you did for the face of the tote.
- Sew the bottom and side panels together as you did for the outside of the tote. Pin along all 3 sides around the tote and machine stitch. Repeat for the other side of the tote. Keep a 4" opening in the middle of the final side so that you can turn the tote to the right side when completed.

Final Assembly:

- Take the remaining piping and machine stitch it to the top edge of the quilted tote RIGHT side. Overlap the raw ends so that the top edge will be clean finished when lining is added.

Hope Tote

Page 5

2. With right sides together, place the lining inside the tote. After matching seams, machine stitch the top edge closed being careful that the handles are inside the bag and do not get caught in the seam.
3. Turn the tote to the outside by pulling it through the opening in the side of the lining. Flatten all seams and press. Add a 1/4" toptstitch at the top of the bag to help the lining stay inside of the bag. Close the opening in the side of the lining with a machine edge stitch.
4. Tack the lining to outside of tote at the 4 corners of the bottom to prevent lining from coming out of the tote.
5. Take the 20" x 9 3/4" bottom insert cover and with right sides together, sew it closed on the long side and one end. Turn and press. Add the Heavy Weight Cardboard or Heavy Weight Pellon insert into the insert cover. Turn the remaining seam allowance inside and slip stitch the opening closed. Place the insert into the bottom of the bag to make it more stiff.

This Hope Tote will make a special gift to give a loved one or special friend that may be going through cancer. This is a great way to show you care!



Be sure to visit www.windhamfabrics.com to see the complete collection and to download other Free Projects